



Large Capacity Checkweigher

DACS-G-S150/300/600

- Superior inspection for large capacity
- Up to 60,000g weighing capacity
- Comprehensive data reporting
- Durable, sanitary design
- User-friendly operation



Model	DACS-G-S150-PB/WP	DACS-G-S300-PB/WP		DACS-G-S600-PB/WP		
Weighing capacity	15,000g (Single-range)	30,000g (Multi-range)		60,000g (Multi-range)		
Weighing range	150~15,000g	150~15,000g	300~30,000g	150~15,000g	300~30,000g	600~60,000g
Minimum graduation	1g	1g	2g	1g	2g	5g
Weighing speed*1	MAX 84 items/min	MAX 60 items/min		MAX 30 items/min		
Weighing accuracy (3σ)*1	±2g~	±2g~	±10g~	±2g~	±10g~	±10g~
Weigh sensor	Double-beam load cell (high output)					
Product dimensions	Length	210mm~590mm		210mm~590/740/1040mm		
	Width	50mm~450mm		50mm~450/500/600mm		
	Height	50mm~450mm		50mm~450/500/500mm		
Belt speed	10~55m/min	10~40m/min		5~20m/min		
Construction	Standard : IP30 (International standard) Waterproof : IP65 (International standard)					
Power supply	Standard : Single phase AC100~120V, Single phase AC200~240V					
Temperature	0°C~40°C (Humidity 30~85%, no condensation)					
Main body weight	Approx. 130kg	Approx. 140kg		Approx. 140kg		
Standard devices	USB slot for data collection*2					
Options	Various options are available. Please contact Heat and Control.					

*1 Weighing accuracy and speed depend on product shape and other conditions.
*2 Use the USB devices which Ishida specifies.

Model	A*	B	C	D
DACS-G-S150-46-PB/WP	400	650	570	460
DACS-G-S300-46-PB/WP	400	650	570	460
DACS-G-S300-58-PB/WP	450	800	620	610
DACS-G-S300-611-PB/WP	550	1100	720	910
DACS-G-S600-46-PB/WP	400	650	570	460
DACS-G-S600-58-PB/WP	450	800	620	610
DACS-G-S600-611-PB/WP	550	1100	720	910

* Available product width for carton is + 50mm up to top plate.
Please refer to "Product dimensions" in the above specification.

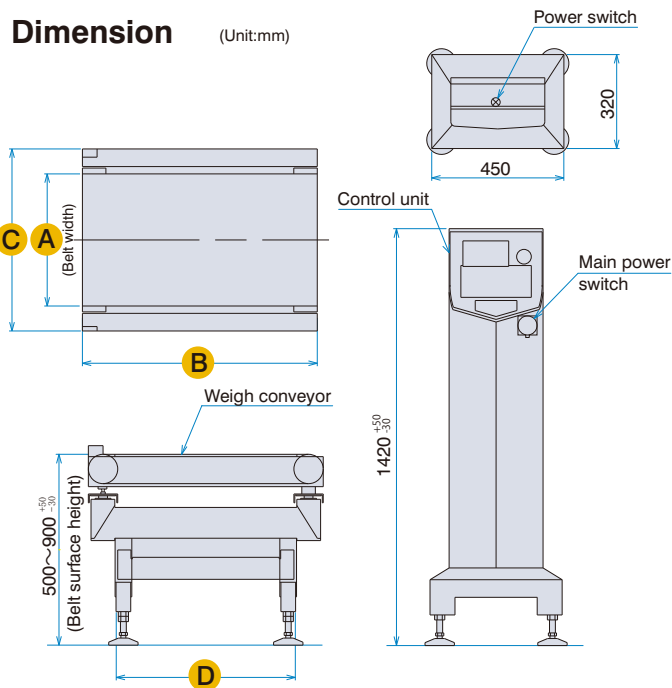

Ishida, the world leader in weighing technology, also manufactures a full line of multihead weighers, X-ray inspection systems, and packaging machines.



Specifications and design are subject to change without notice.



ISHIDA CO., LTD.

44 SANNO-CHO, SHOGOIN, SAKYO-KU
KYOTO, 606-8392 JAPAN
PHONE: 81-75-771-4141
FACSIMILE: 81-75-751-1634
URL: <http://www.ishida.com>



HEAT AND CONTROL, INC.

21121 CABOT BLVD.
HAYWARD, CA 94545-1132 USA
PHONE: 1(800)227-5980
1(510)259-0500
FACSIMILE: 1(510)259-0600
www.heatandcontrol.com
info@heatandcontrol.com